

## DIGITAL INDICATORS (STANDARD TYPE)

DATA OUTPUT

INSPECTION CERTIFICATE

POPULAR MODEL

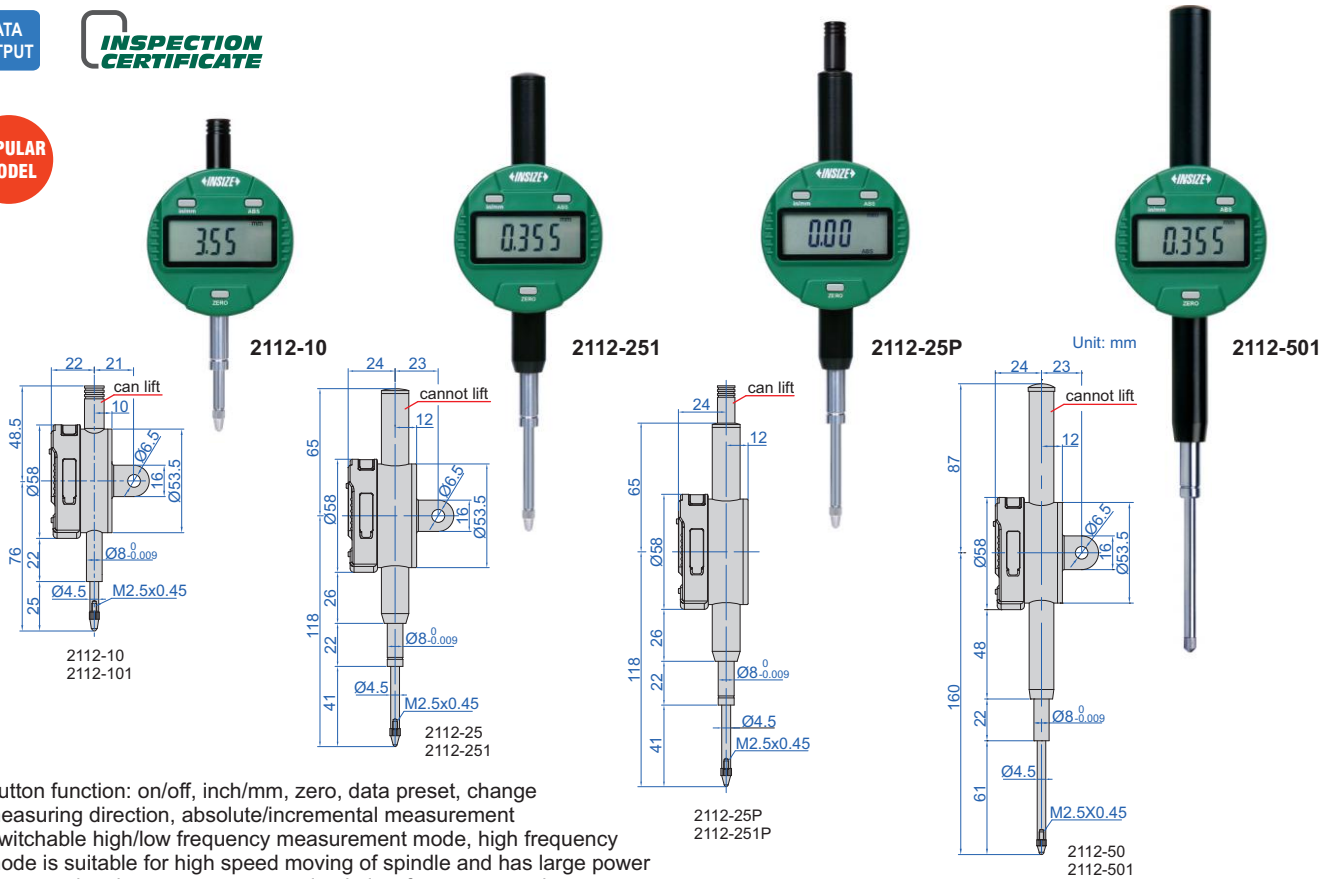

- Button function: on/off, inch/mm, zero, data preset, change measuring direction, absolute/incremental measurement
- Switchable high/low frequency measurement mode, high frequency mode is suitable for high speed moving of spindle and has large power consumption, low power consumption in low frequency mode
- Keep preset data in memory after restart
- CR2032 battery, automatic power off (time is adjustable)
- Data output
- Optional accessory: wireless transmitter code **7315-50M** (receiver is needed) page 6, bluetooth transmitter code **7214-50M** page 12, data output cable code **7302-40M** page 21, **7305-40M** page 17, backs (page 277~278), contact points (page 272~276)

### Resolution 0.001mm/0.00005"

Code	Range	Accuracy	Hysteresis	Maximum measuring force	Cap	Remark
<b>2112-101F*</b>	12.7mm/0.5"	5µm	2µm	1.5N	can lift	flat back
<b>2112-251F*</b>	25.4mm/1"	5µm	3µm	2.2N	cannot lift	flat back
<b>2112-501F*</b>	50.8mm/2"	6µm	3µm	2.5N	cannot lift	flat back
<b>2112-101*</b>	12.7mm/0.5"	5µm	2µm	1.5N	can lift	lug back
<b>2112-251*</b>	25.4mm/1"	5µm	3µm	2.2N	cannot lift	lug back
<b>2112-501*</b>	50.8mm/2"	6µm	3µm	2.5N	cannot lift	lug back
<b>2112-251P*</b>	25.4mm/1"	5µm	3µm	2.2N	can lift	flat back
<b>2112-501P*</b>	50.8mm/2"	6µm	3µm	2.5N	can lift	flat back

### Resolution 0.01mm/0.0005"

Code	Range	Accuracy	Hysteresis	Maximum measuring force	Cap	Remark
<b>2112-10F*</b>	12.7mm/0.5"	20µm	10µm	1.5N	can lift	flat back
<b>2112-25F*</b>	25.4mm/1"	20µm	10µm	2.2N	cannot lift	flat back
<b>2112-50F*</b>	50.8mm/2"	30µm	10µm	2.5N	cannot lift	flat back
<b>2112-10*</b>	12.7mm/0.5"	20µm	10µm	1.5N	can lift	lug back
<b>2112-25*</b>	25.4mm/1"	20µm	10µm	2.2N	cannot lift	lug back
<b>2112-50*</b>	50.8mm/2"	30µm	10µm	2.5N	cannot lift	lug back
<b>2112-25P*</b>	25.4mm/1"	20µm	10µm	2.2N	can lift	flat back
<b>2112-50P*</b>	50.8mm/2"	30µm	10µm	2.5N	can lift	flat back

\*Supplied with manufacturer inspection certificate

2112-251P/501P/25P/50P



spindle lift knob is included



DATA  
OUTPUT

INSPECTION  
CERTIFICATE

## METRIC DIGITAL INDICATORS

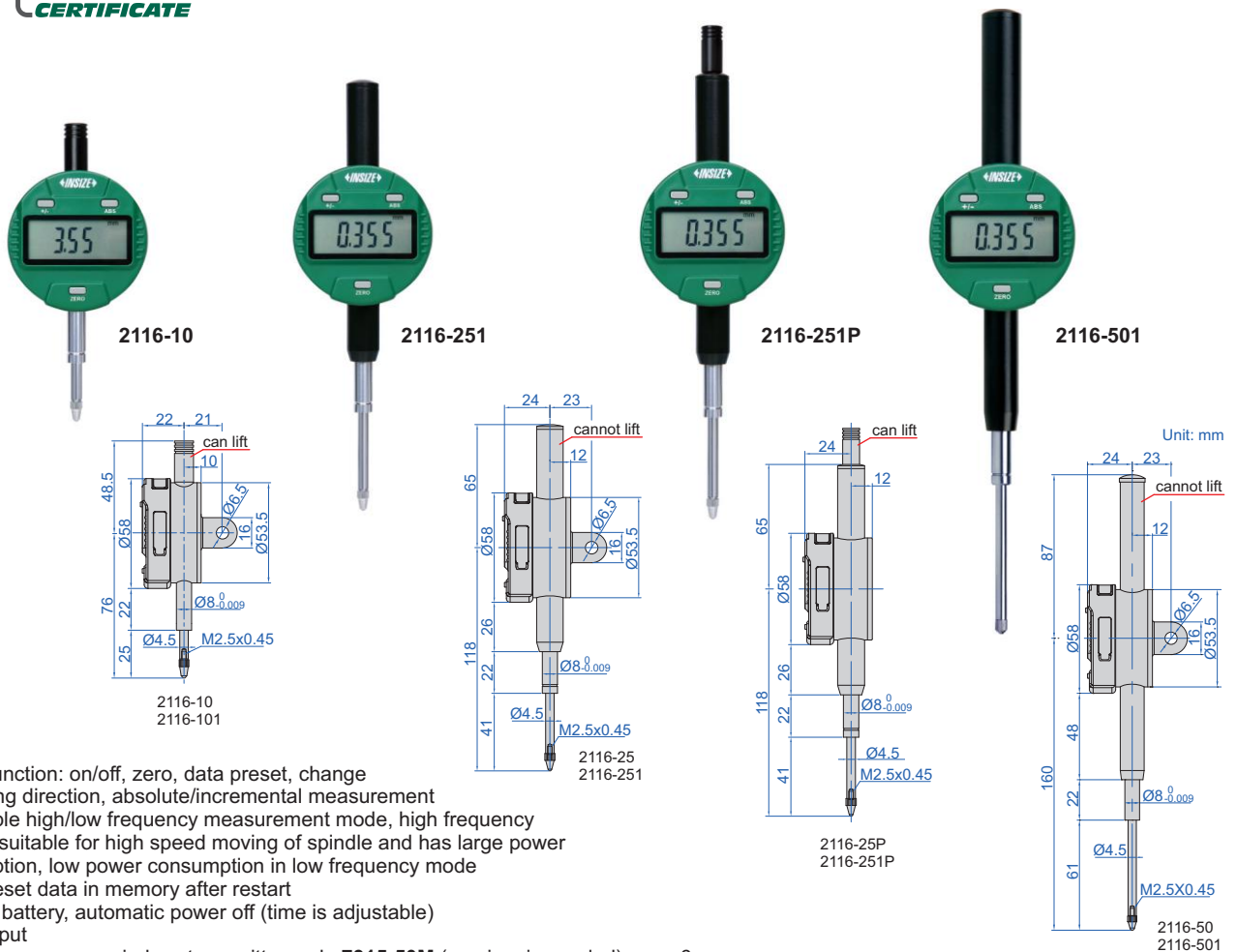

- Button function: on/off, zero, data preset, change measuring direction, absolute/incremental measurement
- Switchable high/low frequency measurement mode, high frequency mode is suitable for high speed moving of spindle and has large power consumption, low power consumption in low frequency mode
- Keep preset data in memory after restart
- CR2032 battery, automatic power off (time is adjustable)
- Data output
- Optional accessory: wireless transmitter code **7315-50M** (receiver is needed) page 6, bluetooth transmitter code **7214-50M** page 12, data output cable code **7302-40M** page 21, **7305-40M** page 17, backs (page 277~278), contact points (page 272~276)

### Resolution 0.001mm

Code	Range	Accuracy	Hysteresis	Maximum measuring force	Cap	Remark
<b>2116-101F*</b>	12.7mm	5µm	2µm	1.5N	can lift	flat back
<b>2116-251F*</b>	25.4mm	5µm	3µm	2.2N	cannot lift	flat back
<b>2116-501F*</b>	50.8mm	6µm	3µm	2.5N	cannot lift	flat back
<b>2116-101*</b>	12.7mm	5µm	2µm	1.5N	can lift	lug back
<b>2116-251*</b>	25.4mm	5µm	3µm	2.2N	cannot lift	lug back
<b>2116-501*</b>	50.8mm	6µm	3µm	2.5N	cannot lift	lug back
<b>2116-251P*</b>	25.4mm	5µm	3µm	2.2N	can lift	flat back
<b>2116-501P*</b>	50.8mm	6µm	3µm	2.5N	can lift	flat back

### Resolution 0.01mm

Code	Range	Accuracy	Hysteresis	Maximum measuring force	Cap	Remark
<b>2116-10F*</b>	12.7mm	20µm	10µm	1.5N	can lift	flat back
<b>2116-25F*</b>	25.4mm	20µm	10µm	2.2N	cannot lift	flat back
<b>2116-50F*</b>	50.8mm	30µm	10µm	2.5N	cannot lift	flat back
<b>2116-10*</b>	12.7mm	20µm	10µm	1.5N	can lift	lug back
<b>2116-25*</b>	25.4mm	20µm	10µm	2.2N	cannot lift	lug back
<b>2116-50*</b>	50.8mm	30µm	10µm	2.5N	cannot lift	lug back
<b>2116-25P*</b>	25.4mm	20µm	10µm	2.2N	can lift	flat back
<b>2116-50P*</b>	50.8mm	30µm	10µm	2.5N	can lift	flat back

\* Supplied with manufacturer inspection certificate

2116-251P/501P/25P/50P



spindle lift knob is included



## DIGITAL INDICATORS (ADVANCED TYPE)



DATA OUTPUT

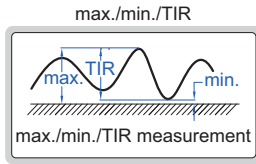
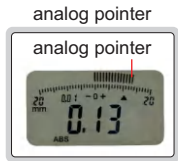
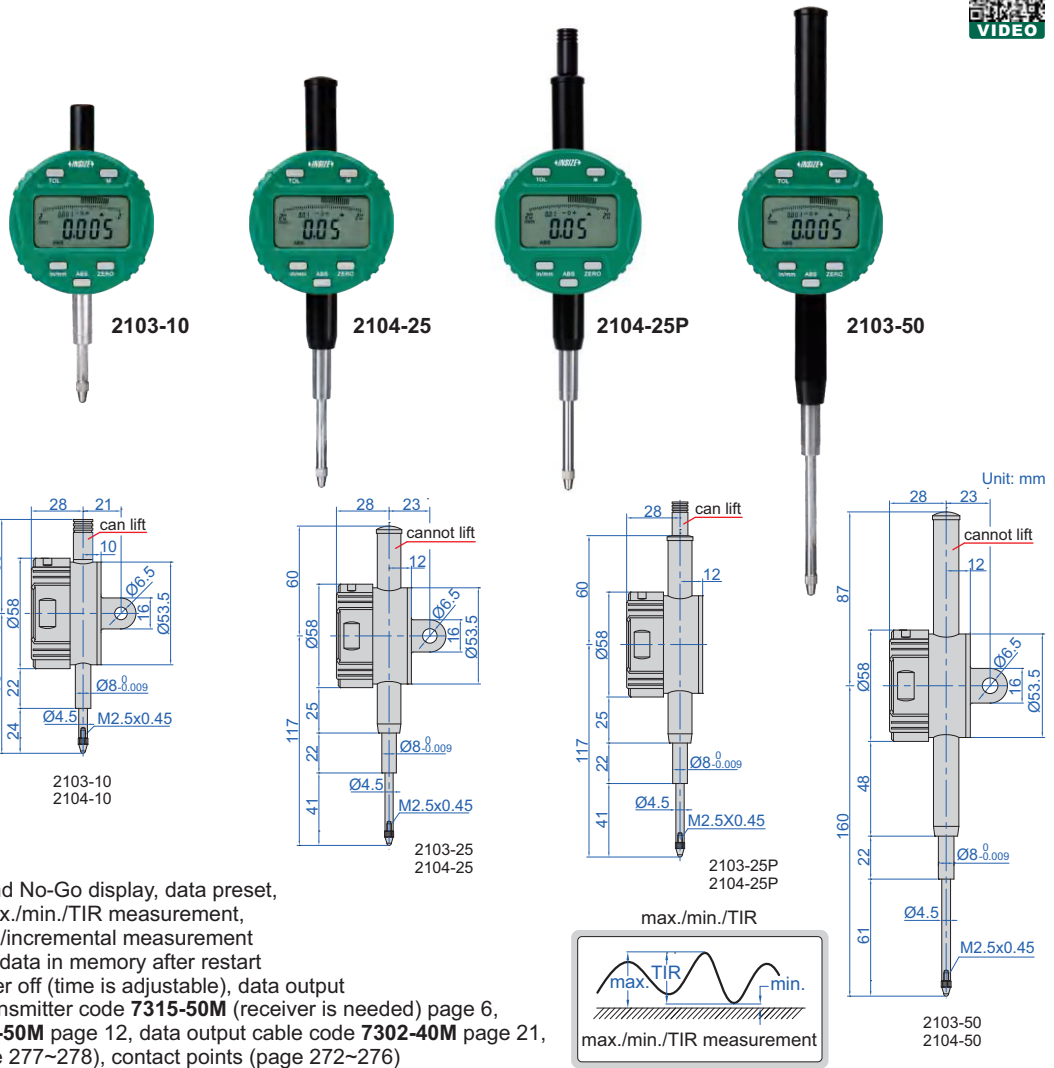

- Reading in digital and analog
- Display can be rotated by 320°
- Button function: tolerance Go and No-Go display, data preset, measuring direction change, max./min./TIR measurement, inch/metric conversion, absolute/incremental measurement
- Keep preset data and tolerance data in memory after restart
- CR2032 battery, automatic power off (time is adjustable), data output
- Optional accessory: wireless transmitter code **7315-50M** (receiver is needed) page 6, bluetooth transmitter code **7214-50M** page 12, data output cable code **7302-40M** page 21, **7305-40M** page 17, backs (page 277~278), contact points (page 272~276)

### Resolution 0.001mm/0.00005"

Code	Range	Accuracy	Hysteresis	Maximum measuring force	Cap	Remark
2103-10F *	12.7mm/0.5"	5µm	2µm	1.5N	can lift	flat back
2103-25F *	25.4mm/1"	5µm	3µm	2.2N	cannot lift	flat back
2103-50F *	50.8mm/2"	6µm	3µm	2.5N	cannot lift	flat back
2103-10 *	12.7mm/0.5"	5µm	2µm	1.5N	can lift	lug back
2103-25 *	25.4mm/1"	5µm	3µm	2.2N	cannot lift	lug back
2103-50 *	50.8mm/2"	6µm	3µm	2.5N	cannot lift	lug back
2103-25P *	25.4mm/1"	5µm	3µm	2.2N	can lift	flat back
2103-50P *	50.8mm/2"	6µm	3µm	2.5N	can lift	flat back

alarm when over tolerance

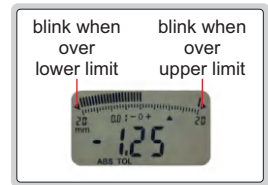

### Resolution 0.01mm/0.0005"

Code	Range	Accuracy	Hysteresis	Maximum measuring force	Cap	Remark
2104-10F *	12.7mm/0.5"	20µm	10µm	1.5N	can lift	flat back
2104-25F *	25.4mm/1"	20µm	10µm	2.2N	cannot lift	flat back
2104-50F *	50.8mm/2"	30µm	10µm	2.5N	cannot lift	flat back
2104-10 *	12.7mm/0.5"	20µm	10µm	1.5N	can lift	lug back
2104-25 *	25.4mm/1"	20µm	10µm	2.2N	cannot lift	lug back
2104-50 *	50.8mm/2"	30µm	10µm	2.5N	cannot lift	lug back
2104-25P *	25.4mm/1"	20µm	10µm	2.2N	can lift	flat back
2104-50P *	50.8mm/2"	30µm	10µm	2.5N	can lift	flat back

2103-25P/50P  
2104-25P/50P



\*Supplied with manufacturer inspection certificate



## DIGITAL INDICATORS (WITH TRANSMISSION BUTTON AND SIGNAL LIGHT)



DATA OUTPUT

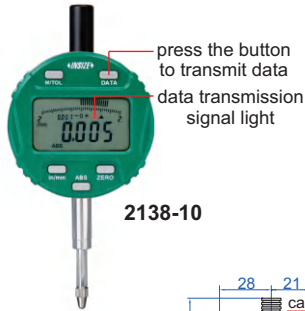

2138-10

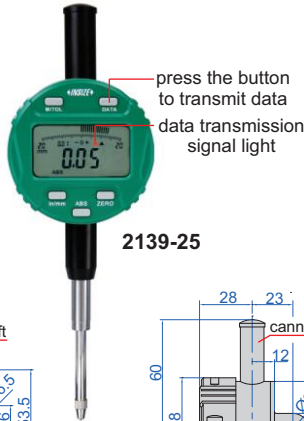

2139-25

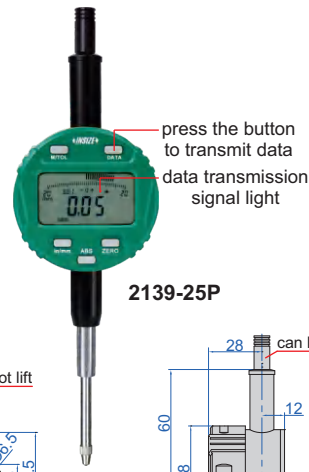

2139-25P



2138-50



spindle lift knob is included

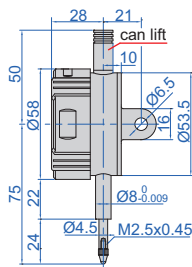

2138-10  
2139-10

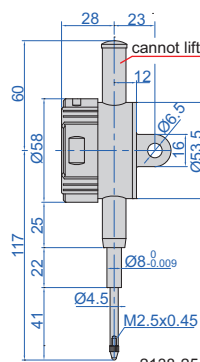

2138-25  
2139-25

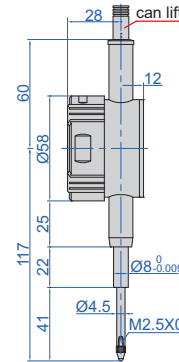

2138-25P  
2139-25P

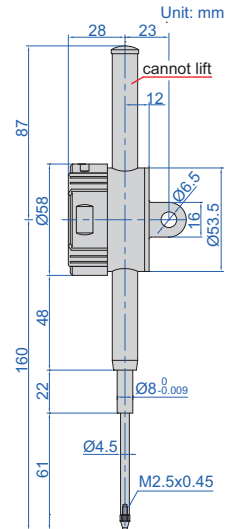

2138-50  
2139-50

- Reading in digital and analog
- Display can be rotated by 320°
- Button function: on/off, zero, tolerance Go and No-Go display, data preset, measuring direction change, max./min./TIR measurement, inch/metric conversion, absolute/incremental measurement, data output
- Keep preset data and tolerance data in memory after restart
- CR2032 battery, automatic power off (time is adjustable)
- Data output
- Optional accessory:
  - flat back: wireless transmitter code **7315-51** (receiver is needed) page 6, bluetooth transmitter code **7214-51** page 12, data output cable code **7302-40M** page 21, **7305-40M** page 17;
  - lug back: wireless transmitter code **7315-50M** (receiver is needed) page 6, bluetooth transmitter code **7214-50M** page 12, data output cable code **7302-40M** page 21, **7305-40M** page 17, backs (page 277~278), contact points (page 272~276)

max./min./TIR

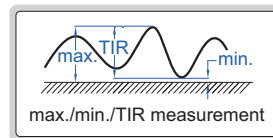

analog pointer

analog pointer



alarm when over tolerance

blink when over lower limit    blink when over upper limit



### Resolution 0.001mm/0.0005"

Code	Range	Accuracy	Hysteresis	Maximum measuring force	Cap	Remark
2138-10F*	12.7mm/0.5"	5µm	2µm	1.5N	can lift	flat back
2138-25F*	25.4mm/1"	5µm	3µm	2.2N	cannot lift	flat back
2138-50F*	50.8mm/2"	6µm	3µm	2.5N	cannot lift	flat back
2138-10*	12.7mm/0.5"	5µm	2µm	1.5N	can lift	lug back
2138-25*	25.4mm/1"	5µm	3µm	2.2N	cannot lift	lug back
2138-50*	50.8mm/2"	6µm	3µm	2.5N	cannot lift	lug back
2138-25P*	25.4mm/1"	5µm	3µm	2.2N	can lift	flat back
2138-50P*	50.8mm/2"	6µm	3µm	2.5N	can lift	flat back

### Resolution 0.01mm/0.0005"

Code	Range	Accuracy	Hysteresis	Maximum measuring force	Cap	Remark
2139-10F*	12.7mm/0.5"	20µm	10µm	1.5N	can lift	flat back
2139-25F*	25.4mm/1"	20µm	10µm	2.2N	cannot lift	flat back
2139-50F*	50.8mm/2"	30µm	10µm	2.5N	cannot lift	flat back
2139-10*	12.7mm/0.5"	20µm	10µm	1.5N	can lift	lug back
2139-25*	25.4mm/1"	20µm	10µm	2.2N	cannot lift	lug back
2139-50*	50.8mm/2"	30µm	10µm	2.5N	cannot lift	lug back
2139-25P*	25.4mm/1"	20µm	10µm	2.2N	can lift	flat back
2139-50P*	50.8mm/2"	30µm	10µm	2.5N	can lift	flat back

2138-25P/50P  
2129-25P/50P



display can be rotated by 320°



pull cap to lift point

\* Supplied with manufacturer inspection certificate

## WATERPROOF DIGITAL INDICATORS

WATERPROOF

DATA  
OUTPUT

INSPECTION  
CERTIFICATE



2115-10

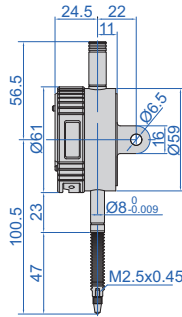

2115-10  
2115-101



2115-25

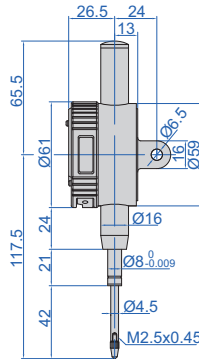

2115-25  
2115-251



2115-50

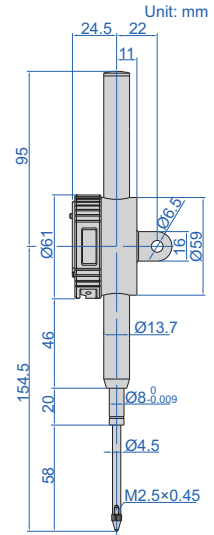

2115-50  
2115-501

- Dust/waterproof
- Button function: on/off, zero, mm/inch, data preset, tolerance, change measuring direction, max./min./TIR measurement, absolute/incremental measurement
- Keep preset data and tolerance data in memory after restart
- CR2032 battery, automatic power off
- Data output
- Optional accessory: wireless transmitter code **7315-50M** (receiver is needed) page 6, bluetooth transmitter code **7214-50M** page 12, data output cable code **7302-40M** page 21, **7305-40M** page 17, backs (page 277~278), contact points (page 272~276)

spindle lift knob is included (except **2115-101/101F**, **2115-10/10F**)



max./min./TIR

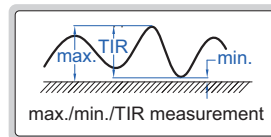

alarm when over tolerance

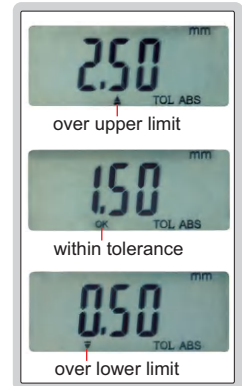

### Resolution 0.001mm/0.00005"

Code	Range	Dust/waterproof	Accuracy	Hysteresis	Maximum measuring force	Cap	Remark
2115-101 *	12.7mm/0.5"	IP65	5µm	2µm	1.5N	cannot lift	lug back
2115-251 *	25.4mm/1"	IP54	5µm	3µm	2.2N	cannot lift	lug back
2115-501 *	50.8mm/2"	IP54	6µm	3µm	2.5N	cannot lift	lug back
2115-101F *	12.7mm/0.5"	IP65	5µm	2µm	1.5N	cannot lift	flat back
2115-251F *	25.4mm/1"	IP54	5µm	3µm	2.2N	cannot lift	flat back
2115-501F *	50.8mm/2"	IP54	6µm	3µm	2.5N	cannot lift	flat back

### Resolution 0.01mm/0.0005"

Code	Range	Dust/waterproof	Accuracy	Hysteresis	Maximum measuring force	Cap	Remark
2115-10 *	12.7mm/0.5"	IP65	20µm	10µm	1.5N	cannot lift	lug back
2115-25 *	25.4mm/1"	IP54	20µm	10µm	2.2N	cannot lift	lug back
2115-50 *	50.8mm/2"	IP54	30µm	10µm	2.5N	cannot lift	lug back
2115-10F *	12.7mm/0.5"	IP65	20µm	10µm	1.5N	cannot lift	flat back
2115-25F *	25.4mm/1"	IP54	20µm	10µm	2.2N	cannot lift	flat back
2115-50F *	50.8mm/2"	IP54	30µm	10µm	2.5N	cannot lift	flat back

\* Supplied with manufacturer inspection certificate



## DIGITAL INDICATORS FOR BORE GAUGES (WITH TRANSMISSION BUTTON AND SIGNAL LIGHT)



THE ORIGINAL DATA  
REMAINS AFTER POWER OFF



DATA  
OUTPUT

- Specially designed for bore gauges
- The minimum value tracking function can find the diameter automatically
- Read the diameter directly, after inputting the size of setting ring
- Reading in digital and analog
- Display can be rotated by 320°
- Button function: on/off, minimum value tracking, calibration, data preset, inch/metric conversion
- Data remains after power off, no need to recalibrate after power on
- CR2032 battery, automatic power off (time is adjustable)
- Data output
- Optional accessory: wireless transmitter code **7315-51B** (receiver is needed) page 7, bluetooth transmitter code **7214-51B** page 12, data output cable code **7302-40M** page 21, backs (page 277~278), contact points (page 272~276), spindle lift knob (code **7332**)



2108-10F

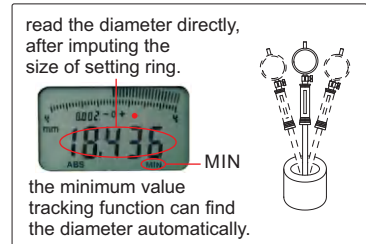
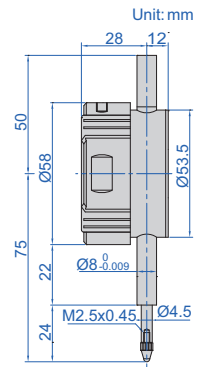

Code	Range	Resolution	Accuracy	Hysteresis	Maximum measuring force	Cap	Remark
2108-10F *	12.7mm/0.5"	0.002mm/0.0001" (can switch to: 0.01mm/0.0005")	20µm	10µm	1.5N	cannot lift	flat back
2108-101F *	12.7mm/0.5"	0.001mm/0.00005"	5µm	2µm	1.5N	cannot lift	flat back

\*Supplied with manufacturer inspection certificate

## WATERPROOF DIGITAL INDICATORS FOR BORE GAUGES



IP54  
WATERPROOF

DATA  
OUTPUT

THE ORIGINAL DATA  
REMAINS AFTER POWER OFF

- Specially designed for bore gauges
- The minimum value tracking function can find the diameter automatically
- Read the diameter directly, after inputting the size of setting ring
- Button function: on/off, minimum value tracking, calibration, data preset, inch/metric conversion
- Data remains after power off, no need to recalibrate after power on
- CR2032 battery, automatic power off (time is adjustable)
- Data output
- Optional accessory: wireless transmitter code **7315-51B** (receiver is needed) page 7, bluetooth transmitter code **7214-51B** page 12, data output cable code **7302-40M** page 21, backs (page 277~278), contact points (page 272~276), spindle lift knob (code **7332**)



2137-10F

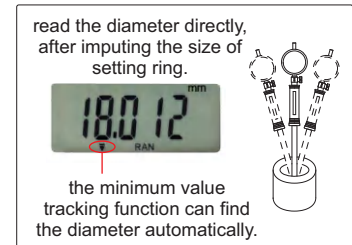

Code	Range	Resolution	Accuracy	Hysteresis	Maximum measuring force	Cap	Remark
2137-10F *	12.7mm/0.5"	0.002mm/0.0001" (can switch to: 0.01mm/0.0005")	20µm	10µm	1.5N	cannot lift	flat back
2137-101F *	12.7mm/0.5"	0.001mm/0.00005"	5µm	2µm	1.5N	cannot lift	flat back

\*Supplied with manufacturer inspection certificate

DATA  
OUTPUT

INSPECTION  
CERTIFICATE

## DIGITAL INDICATORS WITH LIFTING LEVER



2109-10

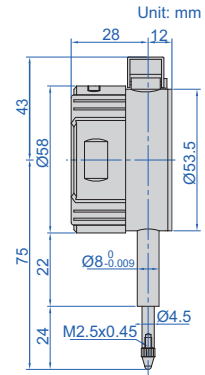

- Reading in digital and analog
- Display can be rotated by 320°
- Button function: tolerance Go and No-Go display, data preset, measuring direction change, max./min./TIR measurement, inch/metric conversion, absolute/incremental measurement
- Keep preset data and tolerance data in memory after restart
- CR2032 battery, automatic power off (time is adjustable)
- Data output
- Optional accessory: wireless transmitter code **7315-50M** (receiver is needed) page 6, bluetooth transmitter code **7214-50M** page 12, data output cable code **7302-40M** page 21, **7305-40M** page 17, backs (page 277~278), contact points (page 272~276)

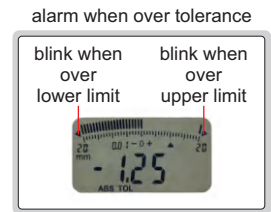
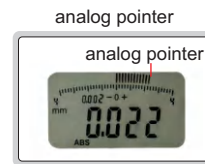

Code	Range	Resolution	Accuracy	Hysteresis	Maximum measuring force	Remark
2109-10 *	10mm/0.4"	0.01mm/0.0005"	20µm	10µm	1.5N	flat back
2109-101 *	10mm/0.4"	0.001mm/0.00005"	5µm	2µm	1.5N	flat back

\* Supplied with manufacturer inspection certificate

10

DATA  
OUTPUT

INSPECTION  
CERTIFICATE

## COMPACT DIGITAL INDICATORS

- Button function:
  - in/mm: short press for inch/metric conversion
  - long press to change measuring direction
  - ABS: short press for absolute/incremental measurement
  - long press to preset data
  - 0/OFF: short press to turn on when power is off
  - short press to set zero when power is on
  - long press to turn off
- Keep preset data in memory after restart
- CR1632 battery, automatic power off
- Data output
- Optional accessory: wireless transmitter code **7315-50M** (receiver is needed) page 6, bluetooth transmitter code **7214-50M** page 12, data output cable code **7302-40M** page 21, **7305-40M** page 17, backs (page 277~278), contact points (page 272~276)



2114-51F

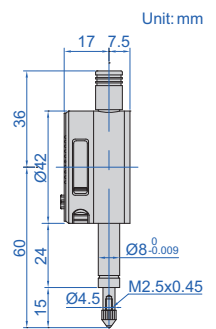

Code	Range	Resolution	Accuracy	Hysteresis	Maximum measuring force	Cap	Remark
2114-5F *	5mm/0.2"	0.01mm/0.0005"	20µm	10µm	1.5N	can lift	flat back
2114-51F *	5mm/0.2"	0.001mm/0.00005"	5µm	2µm	1.5N	can lift	flat back

\* Supplied with manufacturer inspection certificate



## BACK PLUNGER TYPE DIGITAL INDICATORS

INSPECTION  
CERTIFICATE

DATA  
OUTPUT



alarm when over tolerance

blink when over lower limit    blink when over upper limit



analog pointer

analog pointer

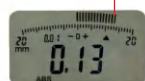

- Display can rotate 320°, and display direction is changeable
- Reading in digital and analog
- Button function: tolerance Go and No-Go display, data preset, measuring direction change, max./min./TIR measurement, inch/metric conversion, absolute/incremental measurement
- Keep preset data and tolerance data in memory after restart
- CR2032 battery, automatic power off (time is adjustable)
- Data output
- Optional accessory: wireless transmitter code **7315-50M** (receiver is needed) page 6, bluetooth transmitter code **7214-50M** page 12, data output cable code **7302-40M** page 21, **7305-40M** page 17, backs (page 277~278), contact points (page 272~276)



2118-10

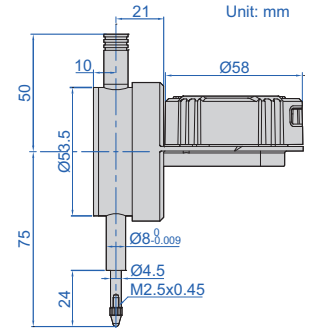

display can rotate 320°



spindle lift knob is included



max./min./TIR

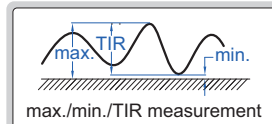

display direction is changeable

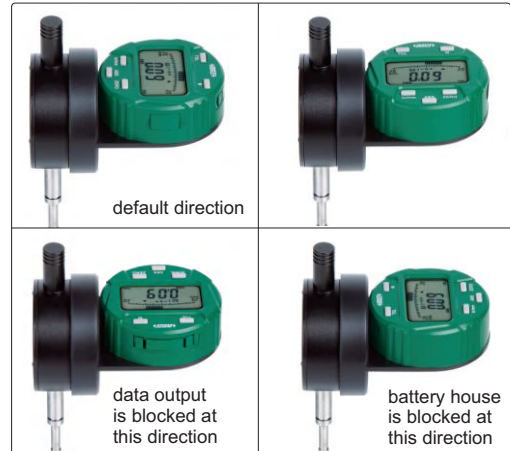

remark: to change above direction, 4 fixing screws on the back of display need to be removed first.

Code	Range	Resolution	Accuracy	Hysteresis	Maximum measuring force	Cap	Remark
2118-10 *	12.7mm/0.5"	0.01mm/0.0005"	20µm	10µm	1.5N	can lift	flat back
2118-101 *	12.7mm/0.5"	0.001mm/0.00005"	5µm	2µm	1.5N	can lift	flat back

\*Supplied with manufacturer inspection certificate

## ZEROING FOOT SWITCH

- For zeroing of digital indicators



7360-1M



Code	Description	Interface of digital indicators	Applicable products
7360-1M	zeroing foot switch with cable (length 2.5m)		for digital indicators

application

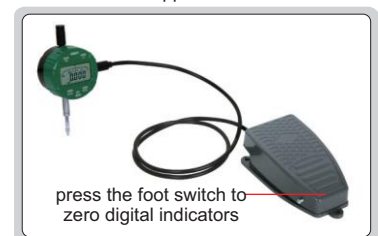

press the foot switch to zero digital indicators

DATA OUTPUT

## LARGE STROKE DIGITAL INDICATORS

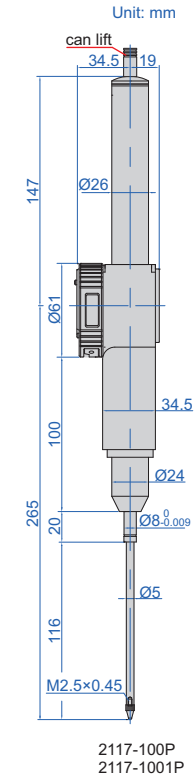
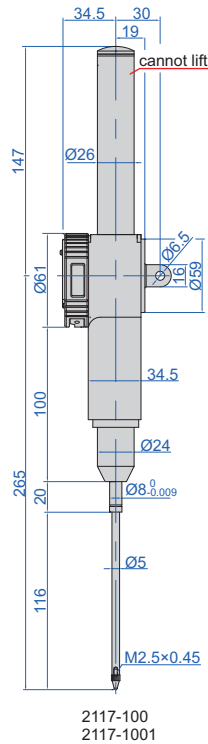

alarm when over tolerance



spindle lift knob is included



2117-100P/1001P



- Button function: on/off, zero, mm/inch, data preset, tolerance, change measuring direction, max./min./TIR measurement, absolute/incremental measurement
- Keep preset data and tolerance data in memory after restart
- CR2032 battery, automatic power off
- Data output
- Optional accessory:
  - wireless transmitter code **7315-50M** (receiver is needed) page 6,
  - bluetooth transmitter code **7214-50M** page 12,
  - data output cable code **7302-40M** page 21, **7305-40M** page 17,
  - backs (page 277-278), contact points (page 272-276)

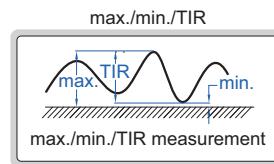

### Resolution 0.01mm/0.0005"

Code	Range	Accuracy	Hysteresis	Maximum measuring force	Cap	Remark
2117-100	100mm/4"	30µm	10µm	3.2N	cannot lift	lug back
2117-100P	100mm/4"	30µm	10µm	3.2N	can lift	flat back

### Resolution 0.001mm/0.00005"

Code	Range	Accuracy	Hysteresis	Maximum measuring force	Cap	Remark
2117-1001	100mm/4"	9µm	3µm	3.2N	cannot lift	lug back
2117-1001P	100mm/4"	9µm	3µm	3.2N	can lift	flat back

## WIRELESS HIGH PRECISION DIGITAL INDICATORS



ABSOLUTE ENCODER, THE ORIGINAL DATA REMAINS AFTER POWER OFF

ATTENTION: RECHARGEABLE BATTERY, FOR 24 HOURS CONTINUOUS WORKING

CONTINUOUS DATA COLLECTION CAN BE CUSTOMIZED (PRESS "DATA" BUTTON TO START CONTINUOUS COLLECTION, PRESS AGAIN TO STOP; COLLECTION FREQUENCY CAN BE CUSTOMIZED, THE FASTEST DATA COLLECTION IS 10PCS PER SECOND)

LINEAR BALL BEARINGS FOR TEN MILLION TIMES USE



alarm when over tolerance

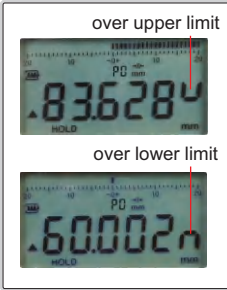

analog pointer

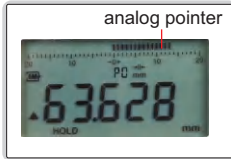

transmit data

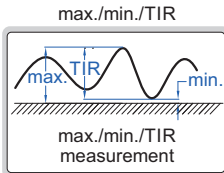
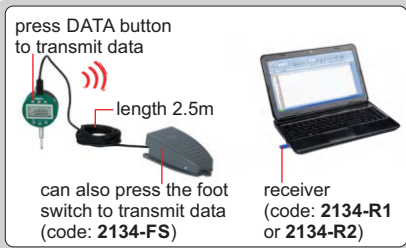

- Built-in wireless transmission, Zigbee single
- Linear ball bearings for ten million times use
- Absolute encoder, the original data remains after power off
- Reading in digital and analog
- Button function: data output, tolerance, data preset, data hold, measuring direction change, max./min./TIR, power off time, on/off, mm/inch, adjust resolution
- Power: rechargeable battery, for 24 hours continuous working
- Optional accessory: contact points (page 272~276), foot switch, code: **2134-FS** wireless receiver, code: **2134-R1** (keyboard format) **2134-R2** (serial port format)

### Standard accuracy

Carbide probe  
Adjustable resolution: 0.0005mm/0.00002"  
0.001mm/0.00005"  
0.01mm/0.0005"

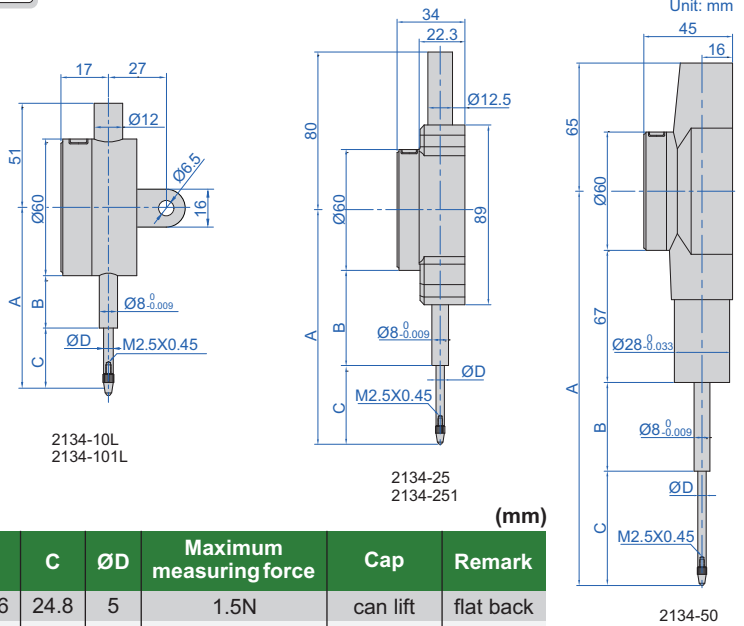

Code	Range	Accuracy	Hysteresis	A	B	C	ØD	Maximum measuring force	Cap	Remark
<b>2134-10*</b>	12.7mm/0.5"	3µm	1.5µm	75.4	20.6	24.8	5	1.5N	can lift	flat back
<b>2134-10L*</b>	12.7mm/0.5"	3µm	1.5µm	75.4	20.6	24.8	5	1.5N	can lift	lug back
<b>2134-25*</b>	25.4mm/1"	3µm	1.5µm	109.5	38.5	41	5	2.2N	cannot lift	flat back
<b>2134-50*</b>	50.8mm/2"	3µm	1.5µm	201	32	72	4.5	2.5N	—	flat back

### High accuracy

Ruby probe  
Adjustable resolution: 0.0002mm/0.00001"  
0.001mm/0.00005"  
0.01mm/0.0005"

Code	Range	Accuracy	Hysteresis	A	B	C	ØD	Maximum measuring force	Cap	Remark
<b>2134-101*</b>	12.7mm/0.5"	1.5µm	1µm	77.4	26	21.4	4	1.5N	can lift	flat back
<b>2134-101L*</b>	12.7mm/0.5"	1.5µm	1µm	77.4	26	21.4	4	1.5N	can lift	lug back
<b>2134-251*</b>	25.4mm/1"	1.8µm	1µm	116.1	42.5	44	4	2.2N	cannot lift	flat back

\*Supplied with manufacturer inspection certificate

spindle lift knob is included



LINEAR BALL BEARINGS FOR TEN MILLION TIMES USE

ABSOLUTE ENCODER, THE ORIGINAL DATA REMAINS AFTER POWER OFF

DATA OUTPUT

ATTENTION: RECHARGEABLE BATTERY, FOR 24 HOURS CONTINUOUS WORKING

## HIGH PRECISION DIGITAL INDICATORS

**INSPECTION CERTIFICATE**

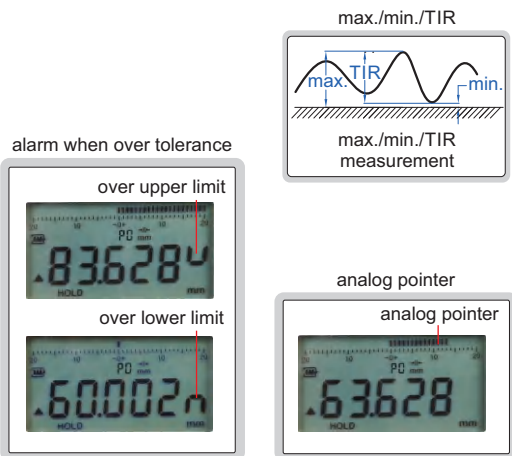

- Linear ball bearings for ten million times use
- Absolute encoder, the original data remains after power off
- Reading in digital and analog
- Data output
- Button function: data output, tolerance, data preset, data hold, measuring direction change, max./min./TIR, power off time, on/off, mm/inch, adjust resolution
- Power: rechargeable battery, for 24 hours continuous working
- Optional accessory: contact points (page 272-276), wireless transmitter code **7315-60** (receiver is needed) page 7, data output cable (keyboard format) code **7302-60** page 21, data output cable (serial port format) code **7305-G60** page 19 (cable length 3m, optional cable length maximum 15m; RS232 protocol, optional RS485 protocol)

### Standard accuracy

Carbide probe  
Adjustable resolution: 0.0005mm/0.00002"  
0.001mm/0.00005"  
0.01mm/0.0005"

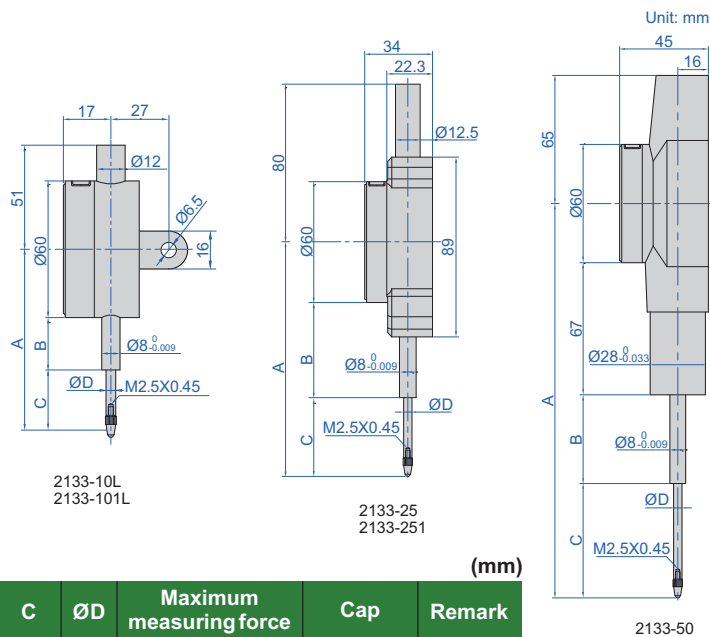

Code	Range	Accuracy	Hysteresis	A	B	C	ØD	Maximum measuring force	Cap	Remark
2133-10*	12.7mm/0.5"	3µm	1.5µm	75.4	20.6	24.8	5	1.5N	can lift	flat back
2133-10L*	12.7mm/0.5"	3µm	1.5µm	75.4	20.6	24.8	5	1.5N	can lift	lug back
2133-25*	25.4mm/1"	3µm	1.5µm	109.5	38.5	41	5	2.2N	cannot lift	flat back
2133-50*	50.8mm/2"	3µm	1.5µm	201	32	72	4.5	2.5N	—	flat back

### High accuracy

Ruby probe  
Adjustable resolution: 0.0002mm/0.00001"  
0.001mm/0.00005"  
0.01mm/0.0005"

Code	Range	Accuracy	Hysteresis	A	B	C	ØD	Maximum measuring force	Cap	Remark
2133-101*	12.7mm/0.5"	1.5µm	1µm	77.4	26	21.4	4	1.5N	can lift	flat back
2133-101L*	12.7mm/0.5"	1.5µm	1µm	77.4	26	21.4	4	1.5N	can lift	lug back
2133-251*	25.4mm/1"	1.8µm	1µm	116.1	42.5	44	4	2.2N	cannot lift	flat back

\* Supplied with manufacturer inspection certificate

spindle lift knob is included



## HIGH PRECISION DIGITAL INDICATORS

ATTENTION: RECHARGEABLE BATTERY, FOR 30 HOURS CONTINUOUS WORKING

IP54 WATERPROOF



ABSOLUTE ENCODER, THE ORIGINAL DATA REMAINS AFTER POWER OFF

Unit: mm



2136-10

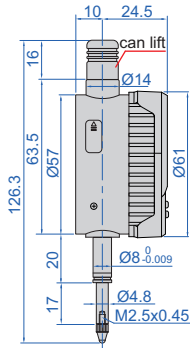

2136-25

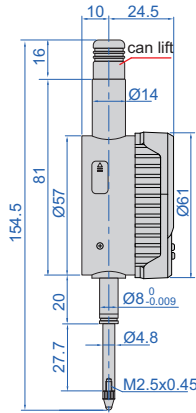

2136-50

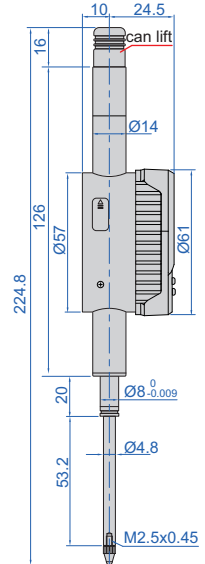

10

- IP54 dust/waterproof (when cap is lifted, no dust/waterproof)
- Absolute encoder, the original data remains after power off
- Automatic power off
- Reading in digital and analog
- Display can be rotated by 270°
- Button function: on/off, zero setting, data preset, tolerance Go and No-Go display, data hold, mm/inch, measuring direction change, max./min./TIR, absolute/incremental measurement, data output
- Data output with USB cable (keyboard format), cable length 1.8 meters, single and continuous transmission (the fastest data output is 40pcs per 10s)
- Power: rechargeable battery, for 30 hours continuous working

analog pointer

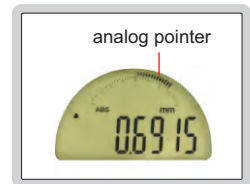

alarm when over tolerance

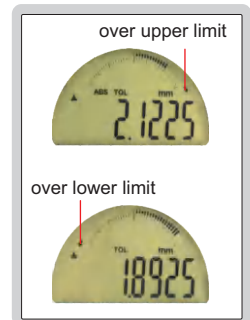

spindle lift knob is included



max./min./TIR

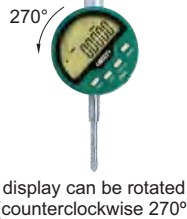
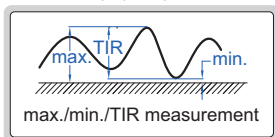

display can be rotated (counterclockwise 270°)



Resolution 0.0005mm/0.00002"

Code	Range	Accuracy	Hysteresis	Maximum measuring force	Cap	Remark
2136-10 *	0-12.7mm/0-0.5"	2µm	1.5µm	1.5N	can lift	flat back
2136-25 *	0-25.4mm/0-1"	2µm	1.5µm	1.8N	can lift	flat back
2136-50 *	0-50.8mm/0-2"	4µm	2µm	2.3N	can lift	flat back

\* Supplied with manufacturer inspection certificate

ATTENTION: RECHARGEABLE BATTERY,  
FOR 30 HOURS CONTINUOUS WORKING

## BLUETOOTH HIGH PRECISION DIGITAL INDICATORS

BUILT-IN  
BLUETOOTH

IP54  
WATERPROOF

COLOR DISPLAY  
LARGE CHARACTERS WITH BACKLIGHT

ABSOLUTE ENCODER, THE ORIGINAL  
DATA REMAINS AFTER POWER OFF

INSPECTION  
CERTIFICATE



2135-10

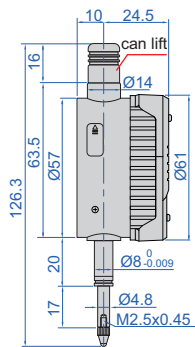

2135-25

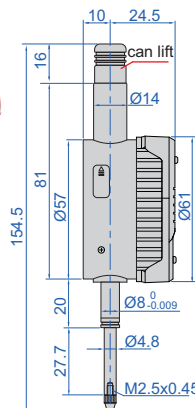

2135-50

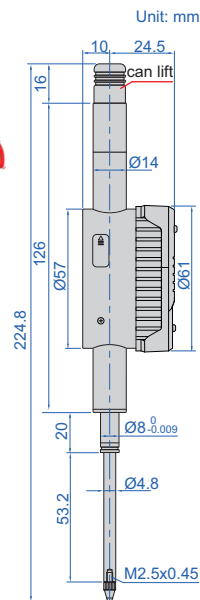

Unit: mm

- IP54 dust/waterproof (when cap is lifted, no dust/waterproof)
- Color display, large characters with backlight
- Absolute encoder, the original data remains after power off
- Automatic power off
- Display can be rotated by 270°
- Adjustable resolution: 0.0005mm/0.00002"  
0.001mm/0.00005"
- Button function: on/off, zero setting, data preset, tolerance Go and No-Go display, data hold, mm/inch, measuring direction change, blue tooth, max./min./TIR, adjust resolution, absolute/incremental measurement, data output
- Android and iPhone APP, USB type-C cable are included
- Power: rechargeable Li-battery, for 30 hours continuous working (bluetooth transmission reduces working hours)

warning in red when over tolerance



spindle lift knob is included



max./min./TIR

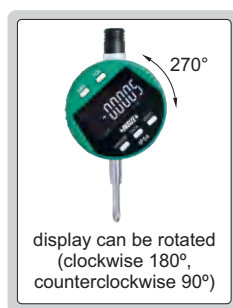
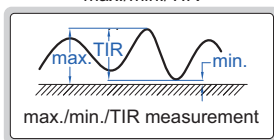

Code	Range	Accuracy	Hysteresis	Maximum measuring force	Cap	Remark
2135-10 *	12.7mm/0.5"	2µm	1.5µm	1.5N	can lift	flat back
2135-25 *	25.4mm/1"	2µm	1.5µm	1.8N	can lift	flat back
2135-50 *	50.8mm/2"	4µm	2µm	2.3N	can lift	flat back

\* Supplied with manufacturer inspection certificate

To be continued

Continued from previous page

**Data output**

Data output with bluetooth (transmission distance is 10 meters)	keyboard format	data can be transmitted to Excel, Word, txt, etc.	single or continuous transmission (the fastest data output is 15pcs per 10s)
	virtual com port	data can be transmitted to Android and iPhone APP	real-time display (continuous transmission) or single transmission
Data output with USB cable (cable length 1.8 meters)	keyboard format	data can be transmitted to Excel, Word, txt, etc.	single or continuous transmission (the fastest data output is 40pcs per 10s)
	virtual com port and 485 data output can be customized		

data output with bluetooth and USB cable (included)

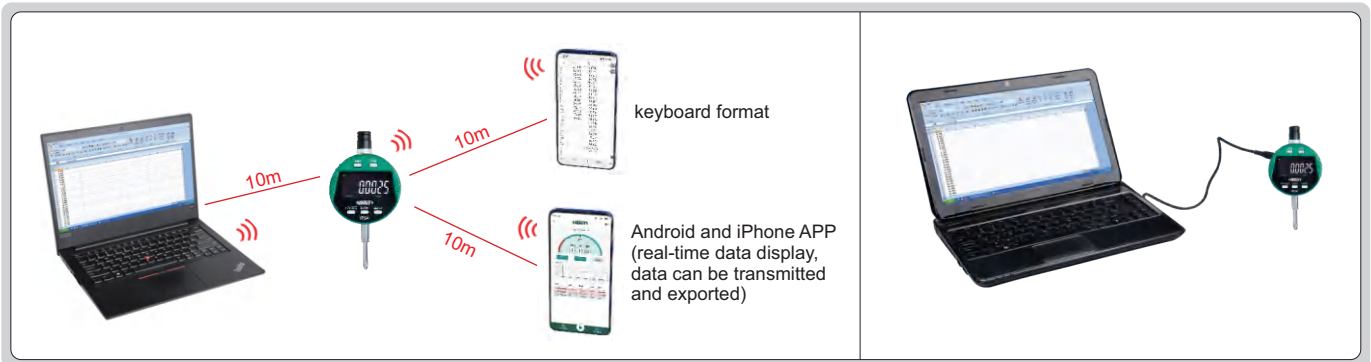

Android and iPhone APP (included), can choose real-time display (continuous transmission) or single transmission

**Real-time data from multiple digital indicators (up to 7pcs simultaneously connected)**

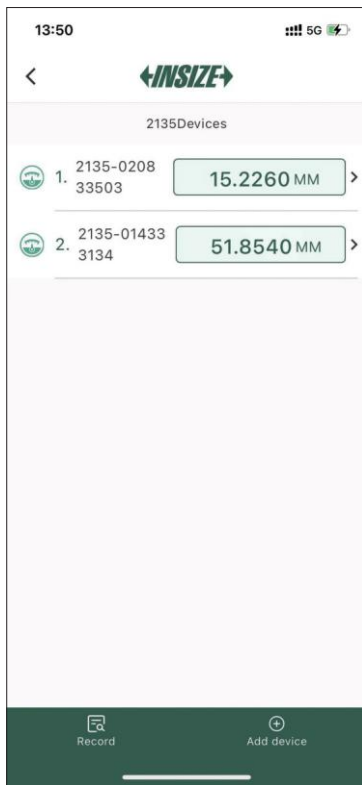

**Transmission interface of single digital indicator**

select continuous or single transmission mode and set parameters and tolerance

indicator dial

real-time data (display in green when within tolerance and display in red when out of tolerance)

graph

red background (out of tolerance)

green background (within tolerance)

send data (EXCEL/PDF/JPEG)

clear data

transmission button

Name	Time	Value	Unit	Status
2135-02083 3503	2024-07-19 13:52:48	20.8160	MM	UpMax
2135-02083 3503	2024-07-19 13:52:47	12.8840	MM	OK

# HIGH PRECISION DIGITAL INDICATORS



DATA OUTPUT

Ø28MM STEM SUITABLE FOR REINFORCED CLAMPING

ABSOLUTE ENCODER, THE ORIGINAL DATA REMAINS AFTER POWER OFF

LINEAR BALL BEARINGS FOR TEN MILLION TIMES USE

ATTENTION: RECHARGEABLE BATTERY, FOR 24 HOURS CONTINUOUS WORKING



2140-6

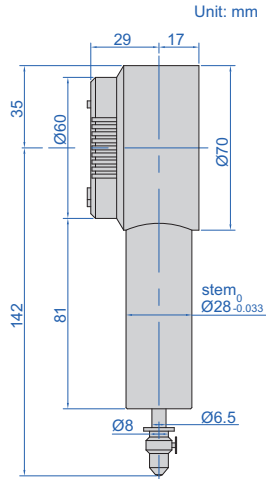

- Linear ball bearings for ten million times use
- Ø28mm stem suitable for reinforced clamping
- Absolute encoder, the original data remains after power off
- Adjustable resolution: 0.0002mm/0.00001"  
0.001mm/0.00005"  
0.01mm/0.0005"
- Reading in digital and analog
- Button function: data output, tolerance, data preset, data hold, measuring direction change, max./min./TIR, power off time, on/off, mm/inch, adjust resolution
- Power: rechargeable battery, for 24 hours continuous working
- Ruby probe

**With data interface**

Optional accessory:  
 wireless transmitter code **7315-60** (receiver is needed) page 7  
 data output cable (keyboard format) code **7302-60** page 21  
 data output cable (serial port format) code **7305-G60** page 19  
 (cable length 3m, optional cable length maximum 15m; RS232 protocol, optional RS485 protocol)

Code	Range	Accuracy	Hysteresis	Maximum measuring force	Remark
2140-6	0-6mm/0-0.24"	1.6µm	0.8µm	1.5N	flat back

**Built-in wireless**

Optional accessory:  
 wireless receiver (keyboard format, connect up to 15 digital indicators), code **2134-R1**  
 wireless receiver (serial port format, connect up to 15 digital indicators), code **2134-R2**

Code	Range	Accuracy	Hysteresis	Maximum measuring force	Remark
2140-6WL*	0-6mm/0-0.24"	1.6µm	0.8µm	1.5N	flat back

\* Continuous data collection can be customized (press "DATA" button to start continuous collection, press again to stop; collection frequency can be customized, the fastest data collection is 10 pcs per second)

alarm when over tolerance

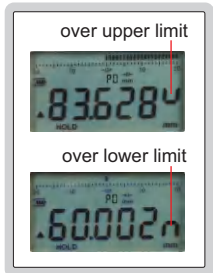

analog pointer



max./min./TIR

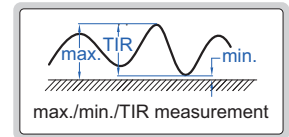

wireless receiver  
2134-R1, 2134-R2 (optional)





## SMART HIGH PRECISION DIGITAL INDICATORS

THE MEASURING TIME PERIOD CAN BE SET (1-99S IS ADJUSTABLE), THE MAX./MIN./TIR/AVG. CAN BE MEASURED AUTOMATICALLY DURING THIS PERIOD, AND THE DATA CAN BE TRANSMITTED AUTOMATICALLY AFTER EACH MEASUREMENT

ATTENTION: RECHARGEABLE BATTERY, FOR 24 HOURS CONTINUOUS WORKING

DATA OUTPUT



PRESS BUTTON OR PROBE MOVEMENT CAN START AUTOMATIC MEASUREMENT, THE MEASUREMENT CAN BE DELAYED (1-99S IS ADJUSTABLE)

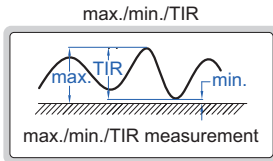

- Linear ball bearings for ten million times use
- Ø28mm stem suitable for reinforced clamping
- Absolute encoder, the original data remains after power off
- Adjustable resolution: 0.0001mm/0.00001"  
0.001mm/0.00005"  
0.01mm/0.0005"
- Reading in digital and analog
- Button function: on/off, adjust resolution, data hold, data output, max./min./TIR/avg., data preset, tolerance, mm/inch, automatic power off, measuring direction change, delay setting, measuring time setting
- Power: rechargeable Li-battery, for 24 hours continuous working
- Ruby probe



2150-5A

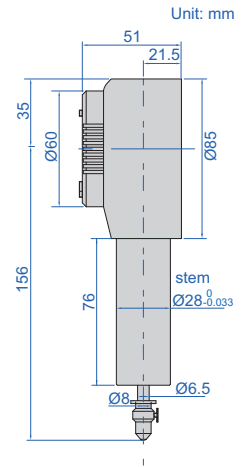

Unit: mm

10

alarm when over tolerance

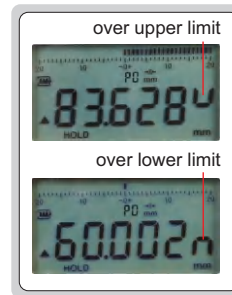

analog pointer

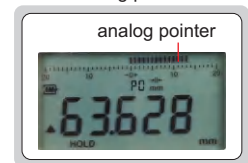

wireless receiver 2134-R1, 2134-R2 (optional)



### With data interface

Optional accessory:  
wireless transmitter code **7315-60** (receiver is needed) page 7  
data output cable (keyboard format) code **7302-60** page 21  
data output cable (serial port format) code **7305-G60** page 19  
(cable length 3m, optional cable length maximum 15m; RS232 protocol, optional RS485 protocol)

Code	Range	Accuracy	Hysteresis	Maximum measuring force	Remark
2150-5A	0-5mm/0-0.2"	0.5µm	0.3µm	1.5N	probe movement starts measurement
2150-5B	0-5mm/0-0.2"	0.5µm	0.3µm	1.5N	press button starts measurement

### Built-in wireless

Optional accessory:  
wireless receiver (keyboard format, connect up to 15 digital indicators), code **2134-R1**  
wireless receiver (serial port format, connect up to 15 digital indicators), code **2134-R2**

Code	Range	Accuracy	Hysteresis	Maximum measuring force	Remark
2150-5AWL *	0-5mm/0-0.2"	0.5µm	0.3µm	1.5N	probe movement starts measurement
2150-5BWL *	0-5mm/0-0.2"	0.5µm	0.3µm	1.5N	press button starts measurement

\* Continuous data collection can be customized (press "DATA" button to start continuous collection, press it again to stop; collection frequency can be customized, the fastest data collection is 10pcs per second)

ATTENTION: RECHARGEABLE BATTERY,  
FOR 12 HOURS CONTINUOUS WORKING

## INDUCTIVE DIGITAL COMPARATOR (HIGH ACCURACY)



IP54  
WATERPROOF

DATA  
OUTPUT

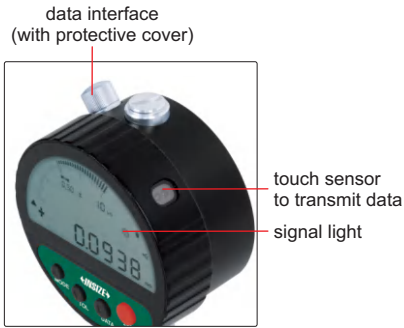

2149-2

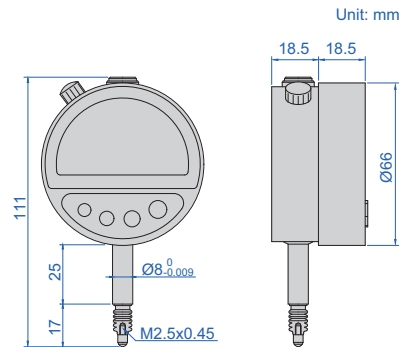

- Built-in wireless transmission
- IP54 dust/waterproof
- Reading in digital and analog
- Display can be rotated by 320°
- Can store 10 set parameters, and the parameter can be searched and recalled
- 999 groups value can be stored
- Touch sensor: use the sensor to transmit data, avoiding press the button to cause deformation of the dial indicator stand and affect the zero position
- Button function: on/off, zero, data hold, measuring direction change, inch/metric conversion, data preset, absolute/incremental measurement, max./min./TIR measurement, tolerance Go and No-Go display, data output, analog pointer resolution and range change, print data
- Power: rechargeable battery, for 12 hours continuous working
- Ruby probe
- Data output
- Optional accessory:  
wireless receiver (code **2149-RE**, transmission distance is 2 meters),  
printer (code **ISF-DF-PRINTER**)

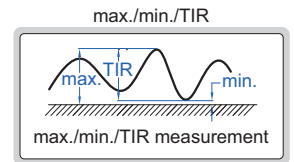

printer (optional)



wireless receiver (optional)



10

Code	Range	Resolution	Accuracy	Hysteresis	Repeatability	Measuring force
2149-2	2mm/0.08"	0.1µm/0.000005"	0.5µm	0.2µm	0.3µm	0.8-1N

## PRECISION DIAL INDICATORS

- Graduation: 0.001mm
- Jeweled bearing
- Supplied with limit pointers and bezel clamp
- Optional accessory: backs (page 277~278), contact points (page 272~276)



2313-1A

JEWELLED  
BEARING

INSPECTION  
CERTIFICATE

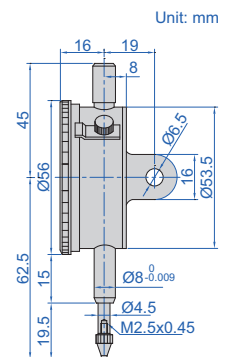

Code	Range	Accuracy	Hysteresis	Range/rev	Dial reading	Maximum measuring force	Cap	Remark
2313-1FA *	1mm	5µm	2µm	0.2mm	0-100-0	2N	cannot lift	flat back
2313-2FA *	2mm	6µm	2.5µm	0.2mm	0-100-0	2N	cannot lift	flat back
2313-1A *	1mm	5µm	2µm	0.2mm	0-100-0	2N	cannot lift	lug back
2313-2A *	2mm	6µm	2.5µm	0.2mm	0-100-0	2N	cannot lift	lug back

\* Supplied with manufacturer inspection certificate

## TRANSFER STANDS

application



rigid construction, designed to make comparison height measurement (set zero with gauge block then measure height of workpiece) with dial indicators or digital indicators (variation of measuring force is high)



6865-300



6865-300T

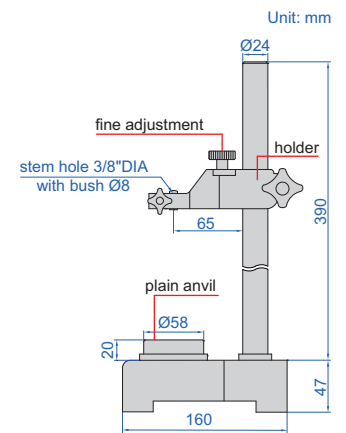

- Vertical travel of holder: 335mm
- Fine adjustment range: 2mm
- Supplied with dust cover

10

Code	Applicable holding stem	Anvil
6865-300	3/8" DIA, $\varnothing 8$ mm	steel (hardness HRC60 $\pm$ 2), plain, flatness 1.5 $\mu$ m
6865-300T	3/8" DIA, $\varnothing 8$ mm	ceramic, plain, flatness 1.5 $\mu$ m

REFER TO PAGE 102-104 FOR DETAILS

## DIGITAL HEIGHT GAUGES



1155-505



1157-501



1158-100